

# SLIDING DOOR HARDWARE KIT

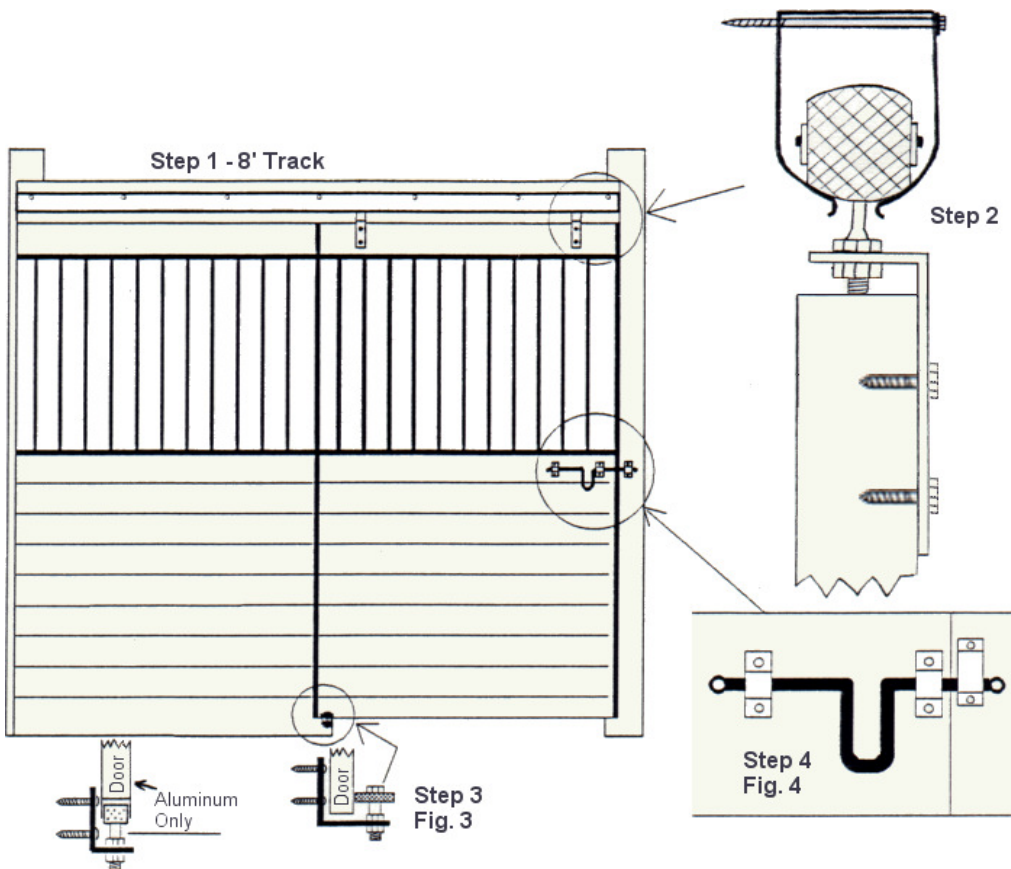

**Bottom Stay Roller Bolts and Nuts**  
 3/8" x 2 1/4" bolt and 2 each 3/8" nuts  
 One Bolt and 2 nuts included in hardware kit



**Lag Bolt 1/4" x 3 1/2"**  
 Five bolts included in each hardware kit



**Lag Screw**  
 5/16" x 1 1/4"  
 Six Screws included in each hardware kit



**Upper Trolley Roller Bolt and Nuts Assembly**  
 Two Bolt and Nut Sets included in each hardware kit



**Wood Screw**  
 1/4" x 1 1/2"  
 Six Screws included in each hardware kit



## INSTALLATION INSTRUCTIONS

1. Install the galvanized track at desired height. First, hold flat side of track against desired position, mark holes, and then drill 1/8" holes every other location. Using the 1/4" x 3 1/2" lag bolts provided, secure the track using 5 each lag bolts equally spaced (do not install the lag bolts in the end holes of the track until the roller trolleys are in place).

2. Attach hanger plate to top board in the door using 5/16" x 1 1/4 lag screws. Hold plates in 6" from outside edge of door and keep "L" portion raised 1" above top of door.
3. Install bottom stay roller assembly (Fig. 3) using two 1/4 x 1 1/2 woodscrews. Position so that there is at least 1/2" clearance between door bottom and bracket.
4. Install door latch assembly (Fig. 4). Position a 2 x 4 or 2 x 6 block as a doorstop at any desired height. Secure the latch in place using 1/4 x 1 1/2 woodscrews.
5. Install an open door stop using a 2 x 4 wooden block positioned to prevent over travel of an opened door.



**Country Manufacturing, Inc.**

P.O. Box 104

Fredericktown, OH 43019

PH: 740-694-9926

FAX: 740-694-5088