

# TANDEM TRAILER MODEL 7550ATV OWNER MANUAL



Manufactured by:  
**Country Manufacturing, Inc.**  
P.O. Box 104  
Fredericktown, OH 43019  
PH: 740-694-9926  
FAX: 740-694-5088

## I. INTRODUCTION

The Model 7550ATV Tandem Axle Trailer is designed for rugged use and versatility. The sideboards are removable from any side allowing unloading from any of the four sides. By removing the four corner stakes the trailer can be converted into a flatbed. Two bed lengths (6 ft. and 7 ft) are available.

CAUTION  
THIS TRAILER IS NOT FOR OVERHIGHWAY USE.

## II. ASSEMBLY INSTRUCTIONS (Refer to Exploded View)

### TOOLS REQUIRED

1/2" wrench  
5/8" wrench  
Pliers

### CHASSIS ASSEMBLY (Refer to FIG. 1)

1. Connect wheel carriers (Item 2) to main chassis (Item 3) using the 3/4" shaft (Item 7). Insert the shaft through the holes in the carrier channel uprights and the 1" welded flanges located on the chassis bottom (make certain the channel uprights are fitted to the outsides of the welded flanges on the bottom of the chassis. Secure with 3/4 washer and 1/8 cotter key.
2. Connect the tongue (Item 1) to the chassis using two 1/2 x 3 bolts, nuts, and lock washers (Item 10). Slide the tongue into the adjustment channel on the chassis. Insert one bolt through the welded adjustment channel and the tongue at the length you require. Insert the hitch piece on the end of the tongue and insert the second bolt through the holes at the hitch end of the tongue. Tighten firmly. (NOTE: if you require a higher hitch height, drill a single hole and insert the 1/2 x 3 bolt at the height you need.)
3. Install the four wheels and secure with 1" washers and 1/4"-cotter keys. Grease all wheels using the fittings provided on the inside of each wheel hub.

### ATTACHING BED TO CHASSIS

1. While holding bed (Item 11) between uprights on the chassis, align the pivot holes located at rear on the angle iron runners on the bottom side of the bed with the two holes on the uprights of the chassis. Once aligned, insert the 1/2" rod (Item 8) through the axle holder and bed holes allowing the bed to pivot. Install cotter pin through hole in 1/2" rod.
2. Install the four bed corner brackets by removing the four bolts located at each corner of the bed and reinserting through the holes of each bracket. Firmly secure using a 5/8" wrench.
3. Install the four 1 x 12 wood boards by inserting each into the slots of each corner stake. Install the two middle angle iron stakes into pockets located midway on the side rails while hooking the top over the sideboard.

## III. MAINTENANCE

1. Periodically grease each of the two wheels via the fittings located inside each hub.
2. Periodically tighten all bolts and check for wear on all pivot joints. Replace as necessary.

**FIG. 1**

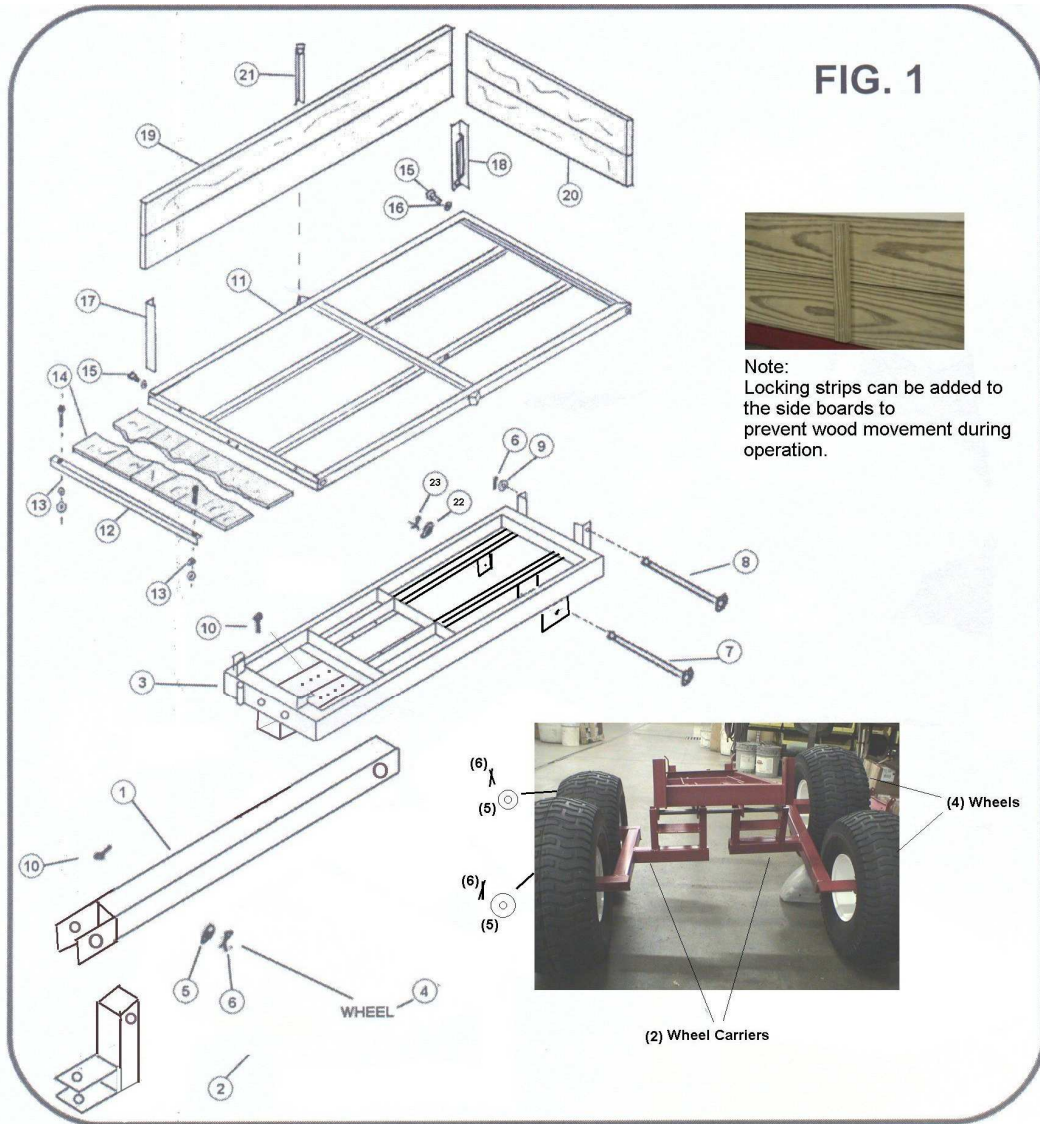

ITEM NO	DESCRIPTION	PART NO	QTY/UNIT
1	Tongue Assembly	5001ATV	1
2	Wheel Carrier	5002ATV	1
3	Chassis	5003	1
4	20-10.00 x 8 Wheel & Tire	5004ATV	4
5	1 inch Flat Washer	5005	4
6	1/4 x 1-1/2 Cotter Pin	5006	4
7	Wheel Carrier Shaft	5006	1
8	Bed Pivot Shaft	5008	1
9	1/2 inch Washer	5009	1
10	1/2 x 3 bolt/nut/washer	50010	2
11	Bed Frame	50011	1
12	Bed Frame Angle	50012	1
13	5/16 x 1 1/2 bolt/nut/washer	50013	2
14	Floor Board	50014	7
15	7/16 x 3/4 Bolt	50015	4
16	7/16 Washer	50016	4
17	Right Corner Bracket	50017	2
18	Left Corner Bracket	50018	2
19	Side Board	50019	2
20	End Board	50020	2
21	Side Stake	50021	2
22	1/8 Cotter Key	50022	4
23	3/4 inch Washer	50023	1

## **WARRANTY POLICY**

Country Manufacturing, Inc., will, at its option, replace or repair, without charge to the original purchaser any part or parts manufactured by it and found upon examination, to be DEFECTIVE IN MATERIAL AND/OR WORKMANSHIP if received for such examination within 90 days from date of original purchase.

Damage resulting from accident, abuse or neglect are conditions under which warranty cannot be claimed. Nor will warranty apply to damage resulting from failure to follow the Manufacturer's instruction for operation and maintenance nor from the improper selection of a particular application.

All transportation charges on, and damages and loss incurred in connection with the transportation of, parts submitted for replacement or repair under this WARRANTY shall be borne by the purchaser.

No other warranties, guarantees, or liabilities, either implied or expressed, will be the responsibility of Country Manufacturing, Inc.