

TOOLS REQUIRED

3/4" WRENCH AND SOCKET
9/16" WRENCH AND SOCKET
PLIERS

SAFETY INSTRUCTION

DO NOT CARRY PASSENGERS IN CART.
DO NOT TOW CART ON PUBLIC ROADS.
NEVER EXCEED LOAD CAPACITY - 1000LBS.
AVOID SUDDEN TURNS OR MANEUVERS.
WHEN OPERATING ON SLOPES, USE LOWEST
GROUND SPEED AND LIMIT LOAD TO 200LBS.
OPERATE UP AND DOWN SLOPES, NEVER
ACROSS THE FACE.

MAINTENANCE

CHECK TIRE PRESSURE REGULARLY
(5 PSI RECOMMENDED.)
GREASE WHEELS AT AXLE FOR LONGER LIFE.
PERIODICALLY CHECK ALL BOLTS.
KEEP CART CLEAN TO PREVENT RUST.
STORE INSIDE A CLEAN DRY AREA.

*NOTE: DO NOT TIGHTEN
BOLTS AT THIS TIME. THEY
WILL BE TIGHTENED AFTER
AXLE AND WHEELS HAVE
BEEN INSTALLED IN A
LATER STEP.*

CARTON CONTENTS		
REF.NO.	QTY.	DESCRIPTION
1	1	BED ASSEMBLY
2	1	FRONT SUPPORT
3	4	AXLE HOLDER PLATE
4	1	HITCH
5	1	HITCH BRACKET
6	1	FRONT SUPPORT PIN
7	1	AXLE
8	2	ATV TIRES - IN BOX 2
22	1	ASSEMBLY MANUAL
23	1	BOLT BAG
BOLT BAG CONTENTS		
9	18	3/8" X 3/4" HEX BOLT
11	18	3/8" LOCK NUT
12	2	1/2" X 2-3/4" HEX BOLT
13	2	1/2" LOCK WASHER
14	2	1/2" FLAT WASHER
15	2	1/2" HEX NUT
16	2	1" AXLE WASHER USS
17	2	COTTER PIN
18	1	HAIR PIN COTTER
19	2	REFLECTOR
20	4	PVC AXLE SPACER
21	4	TUBE CAP PLUGS

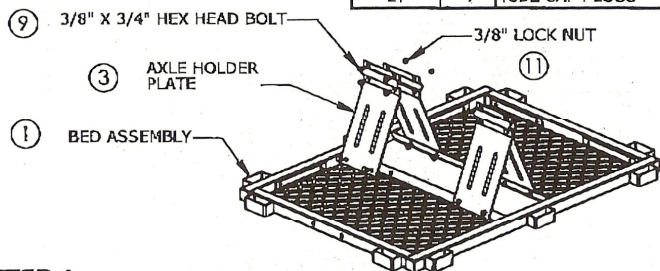

STEP 1.

- Lay cart bed upside down to install axle holder plates.
- Add four axle holder plates to undercarriage plate, as shown, with eight 3/8" x 3/4" hex bolts, and 3/8" lock nuts. **NOTE: DO NOT TIGHTEN AT THIS TIME.**
- Loosely bolt together the axle holder plates with eight 3/8" x 3/4" hex bolts and 3/8" lock nuts.

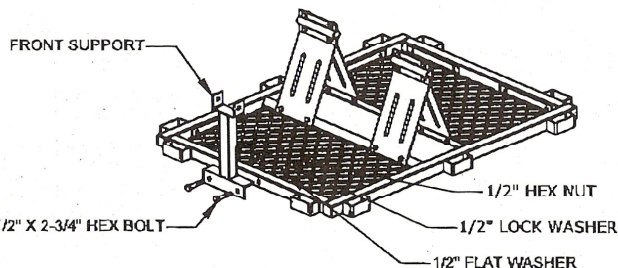

STEP 2.

- Place front support assembly onto front of cart, as shown.
- Insert two 1/2" x 2 1/2" hex bolts through front support angle holes, and holes in cart bed tube.
- Secure in place with two 1/2" flat washers, two 1/2" lock washers, and two 1/2" hex nuts.

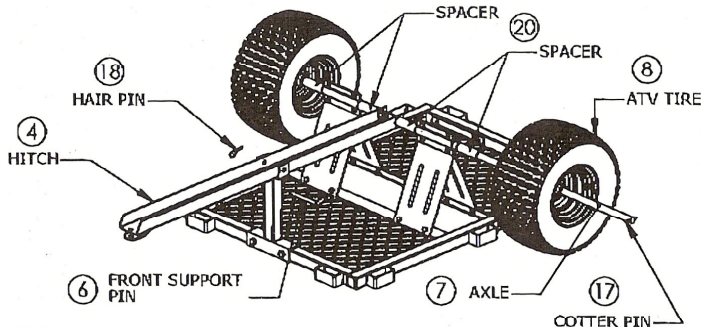

STEP 3.

- Slide axle through axle holder plates, add spacer, drawbar, add another spacer then through other set of axle plates.
- Center axle and add another spacer, axle washer, tire, axle washer, in that order to each side and secure in place by adding cotter pin in axle and spreading ends.
- Insert drawbar pin through front support assembly and drawbar, lock in place with hair pin.
- At this time, tighten ALL bolts. **NOTE: TIGHTEN ALL BOLTS.**

Distributed By:
Country Manufacturing Inc.
www.countrymanufacturing.com
 1-800-335-1880

Repair Parts List

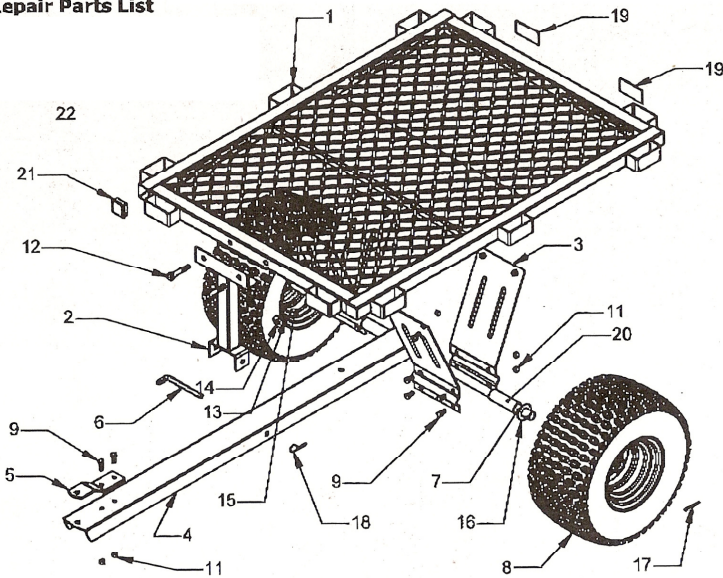

FLATBED ATV DUMP CART
 ASSEMBLY MANUAL AND PARTS LIST

CAUTION:
 READ AND FOLLOW
 ALL SAFETY
 INSTRUCTIONS
 BEFORE USING
 THIS EQUIPMENT.

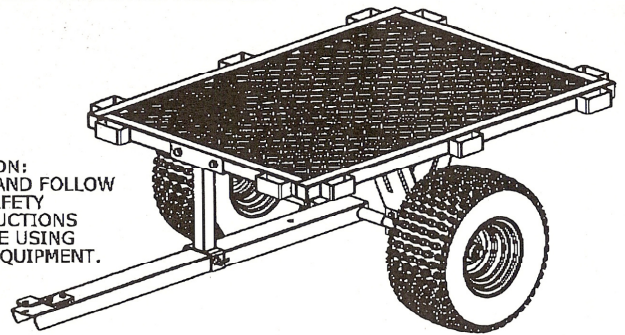

REF. NO.	PART NO.	QTY.	DESCRIPTION	REF. NO.	PART NO.	QTY.	DESCRIPTION
1	524001	1	BED ASSEMBLY	14	300075	2	1/2" FLAT WASHER USS
2	524021	1	FRONT SUPPORT	15	3000613	2	1/2" HEX NUT
3	424271	4	AXLE HOLDER PLATE	16	3000973	4	1" AXLE WASHER USS
4	424101	1	HITCH	17	3000087	2	COTTER PIN 3/16" X 1-1/2"
5	424121	1	HITCH BRACKET	18	3000984	1	HAIR PIN COTTER
6	424871	1	FRONT SUPPORT PIN	19	300151	2	REFLECTOR SATELITE 2015
7	3000003	1	AXLE 1" DIA.	20	3001210	4	PVC SPACER 3-13/16"
8	3000109	2	ATV TIRE	21	300222	4	1-3/4" SQUARE PLUG
9	3000532	16	3/8" X 3/4" HEX BOLT	22	322962	1	ASSEMBLY MANUAL
10	3000081	16	3/8" LOCK NUT	23	323031	1	BOLT BAG
11	3000524	2	1/2" X 2-3/4" HEX BOLT				
12	3000714	2	1/2" LOCK WASHER				

Standard hardware items can be purchased locally.

For missing parts or questions call 1-800-652-2321

LIMITED ONE-YEAR WARRANTY

If this product fails due to a defect in material or workmanship within one year from the date of purchase, we will at our option repair or replace it free of charge. This warranty excludes tires and wheels, which are expendable and become worn during normal use.

This warranty does not cover:

- Repairs necessary because of operator abuse or negligence.
- Equipment used for commercial or rental purposes.

Proof of Purchase Required For All Warranty Claims.

ORDERING INFORMATION

After the one year warranty period all parts maybe ordered by calling 1-800-652-2321.

When ordering repair parts, always give the following information:

- Product -
- Model Number -
- Part Number -
- Part Description -